

# HILLIARD

## RAINER SCONCE



### DESIGN:

Masterfully chiseled to a cylindrical shape showcasing its raw, earthy texture. The Rainier sconce is skillfully held in a cast bronze, frame hand finished in a fine hammered texture.

### FINISHES SHOWN:

Hand Carved Selenite Stone and Hammered Antique Bronze Frame, additional finishes available.

# HILLIARD

## RAINER SCONCE

**DIMENSIONS:** Each Pendant: 16 x 5.5 x 4 IN  
41 x 14 x 10 CM

**WEIGHT:** APPROX 25 LBS

**VOLTAGE:** 120v standard / 240 available  
UL DAMP LISTED/ CE AVAILABLE

**J-BOX REQUIREMENT:** Standard

**LAMPING PER PENDANT:** (1) 5W DIMMABLE LED BULBS INCLUDED  
600 LUMENS EACH - 2700k or 3000k.  
120V : G8 candelabra LED  
240V : G8 candelabra LED

CA title 24

Each fixture is hand crafted, signed, and numbered in Arcata, CA

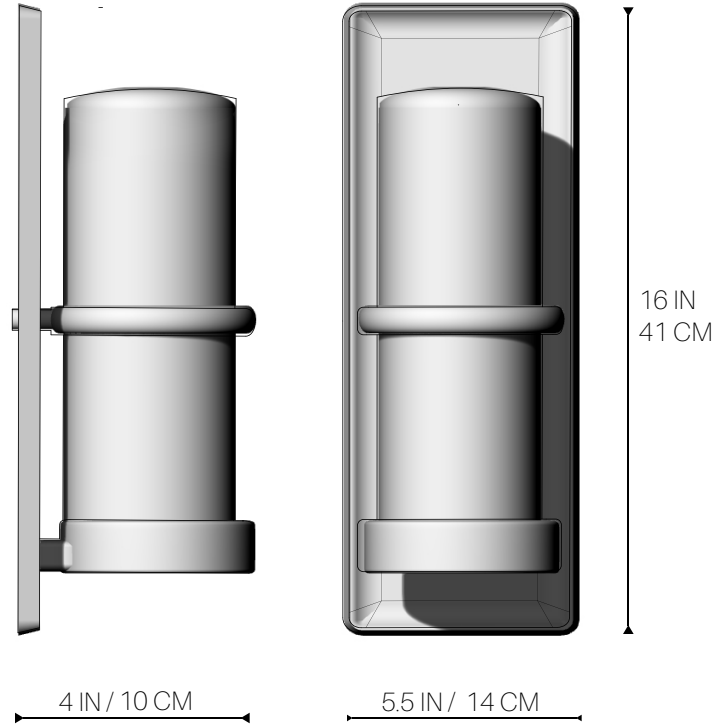

## RAINER SCONCE MATERIALS

STANDARD FINISHES AVAILABLE

CONTACT  
INFO@HILLIARDLAMPS.COM  
FOR CUSTOM REQUESTS



CARVED  
SELENITE STONE

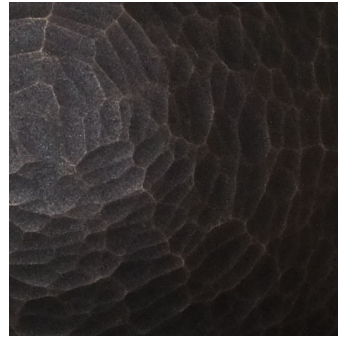

HAMMERED ANTIQUE  
BRONZE

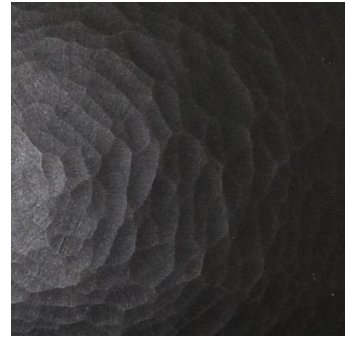

HAMMERED MATTE  
BLACK BRONZE

# HILLIARD

